

**CITY OF DAYTON**  
**Public Works Design Standards**

---

**Stormwater Detention Systems, Purpose & Example Summary**

**Appendix I**

---



## **Stormwater Detention**

The primary purpose of stormwater detention is to mitigate the impacts of new development on downstream drainage systems and downstream properties. As property develops, the increased impervious area generates increased stormwater runoff due to a couple of factors. First, a larger portion of the rainfall is discharged from the site, since pervious surfaces (*bare or vegetated ground*) allow more of the water to soak into the ground and not leave the site than do impervious surfaces (*ie. pavement, roofs, sidewalks, compacted gravel, etc. associated with development*). Second, impervious surfaces allow the stormwater to travel across the site more quickly, resulting in a greater concentration of water in a shorter time period, thus producing higher peak runoff rates. By capturing the runoff from developed areas in a detention facility, the opportunity is created to release the resultant runoff at a controlled rate, with the discharge rate. Allowable runoff is typically permitted to be no more than the estimated flow from the site under pre-developed conditions, or the capacity of the downstream conveyance system, whichever is less.

The City's current detention standard is outlined in Division 3 of the Public Works Design Standards (PWDS). City standards require a development to control the flowrate of stormwater run-off to the flowrate that was generated by a defined storm under pre-development conditions (*unless there are downstream capacity issues which would require an even lower discharge flowrate*). The stormwater detention storage facility must be sized to contain the difference between the defined post-development storm (*ie. runoff under post-development conditions*) and the defined predevelopment storm (*ie. runoff under pre-development conditions*).

Figures 5-4 and 5-5 show the runoff from a hypothetical 5-acre site. It is a grassy field in its undeveloped condition, and developed as a commercial site. Figure 5-4 provides a comparison of undeveloped run-off and developed runoff for a 10-year storm event on the same property. This gives a picture of pre-developed and post-developed runoff based on the same storm event. For example, where City standards require calculations based on a 5-year pre-developed storm and a 25-year post-developed storm, Figure 5-5 presents runoff for those events and also shows the discharge from a detention basin where the release is restricted to the peak flow of the 5-year storm event.

There are several benefits provided by stormwater detention systems. The first relates to the local system immediately downstream of the site. As shown by Figure 5-5, the peak release rate from the detention facility is limited to the peak flow rate from a 5-year storm in the predeveloped condition. The resulting 2.2 cfs discharge is much more easily handled by the downstream stormwater system than would be the case if the 5.8 cfs discharge occurred from a development without a stormwater detention system (*in this case, the peak flowrate would be more than doubled without detention*).

Another potential benefit of detention relates to controlling the demand placed on the downstream trunk storm systems and drainage channels. The impact of runoff and detention is cumulative. As multiple sub-basins discharge into the main stormwater conveyance system, the impact of undetained runoff increases. This issue is particularly important for the

City, since the time of concentration is relatively short for many of the drainage basins, resulting in comparatively large percentage increases in basin run-off that all occur close to simultaneously. The timing consideration for the cumulative runoff is important. For larger basins where the upper end of the basin is a long distance from the middle or lower end of the basin, the peak flows become offset in time and do not fully add together to produce the same percentage increase in the combined peak flows as experienced in smaller basins.

In addition to the reduced capacity impacts on the downstream storm conveyance system, detention provides benefits by reducing the erosion and silt impacts caused by the stormwater runoff. Detention systems typically capture some sediment either in the flow control structure or in the detention storage area itself, reducing the amount of sediment flowing to the downstream system. Downstream of detention, reduced flows in open channels also cause less erosion than would typically be experienced under the higher undetained flows. Finally, where drainage basins discharge to major drainageways, the reduced flows cause less erosion potential due to combined basin flow discharges into the creek or river.

While stormwater detention has potential benefits when properly implemented, it is not without costs. One potential cost is loss of developable land. Some of the simplest and least expensive detention facilities are open storage ponds created on a site. A second method of creating detention capacity is to do so with underground vaults, pipes or chambers. While this method is more expensive to construct, it typically allows the development of a greater percentage of the site. Whether constructed above or below ground, detention facilities also result in long-term maintenance requirements for the responsible party, which incurs additional cost over time.

To protect the local system adjacent to potential development sites, and also to protect the major storm drainage trunk system, the City have implemented stormwater detention requirements in the PWDS.

As described above, the basic principle of detention is to capture the runoff before it leaves a site, hold it in some form of storage system, and release it at a metered rate to the downstream stormwater conveyance system, in order to avoid increases in flow that the downstream system may not be able to handle. As noted above, detention can be accomplished a number of different ways. Options used for storage include open storage basins, storage in landscape areas, ponding in parking lot areas, underground storage pipes or storage chambers. Different forms of storage can be combined at one facility, such as a ponding in a parking lot and an underground pipe. Several examples are shown in Figures 5-6 through 5-9.

The most common method of controlling the discharge rate is a flow control structure with an orifice that restricts the ability of the water to flow into the discharge pipe. Flow control orifices are typically installed in manholes or stormwater inlets. A standard example of a flow control manhole is shown by PWDS Detail 320, whereas flow control Type III inlet as shown by Figure 5-11 may be used where there is not enough depth for a standard flow control manhole (*these are illustrative samples only, and any flow control structure must meet current City standards*).

Figure 5-4 | Pre & Post Development Runoff

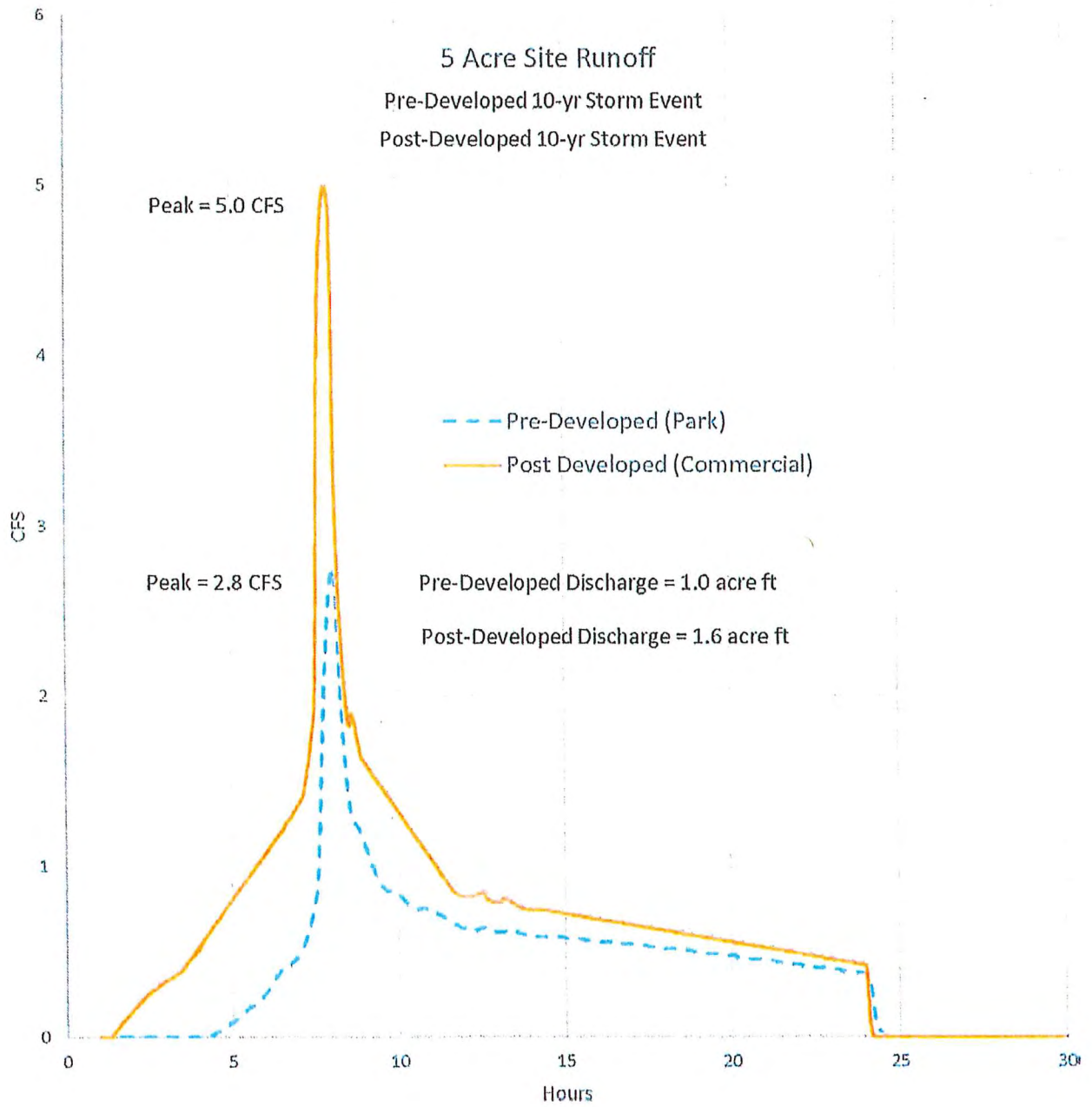

Figure 5-5 | Site Runoff With Detention

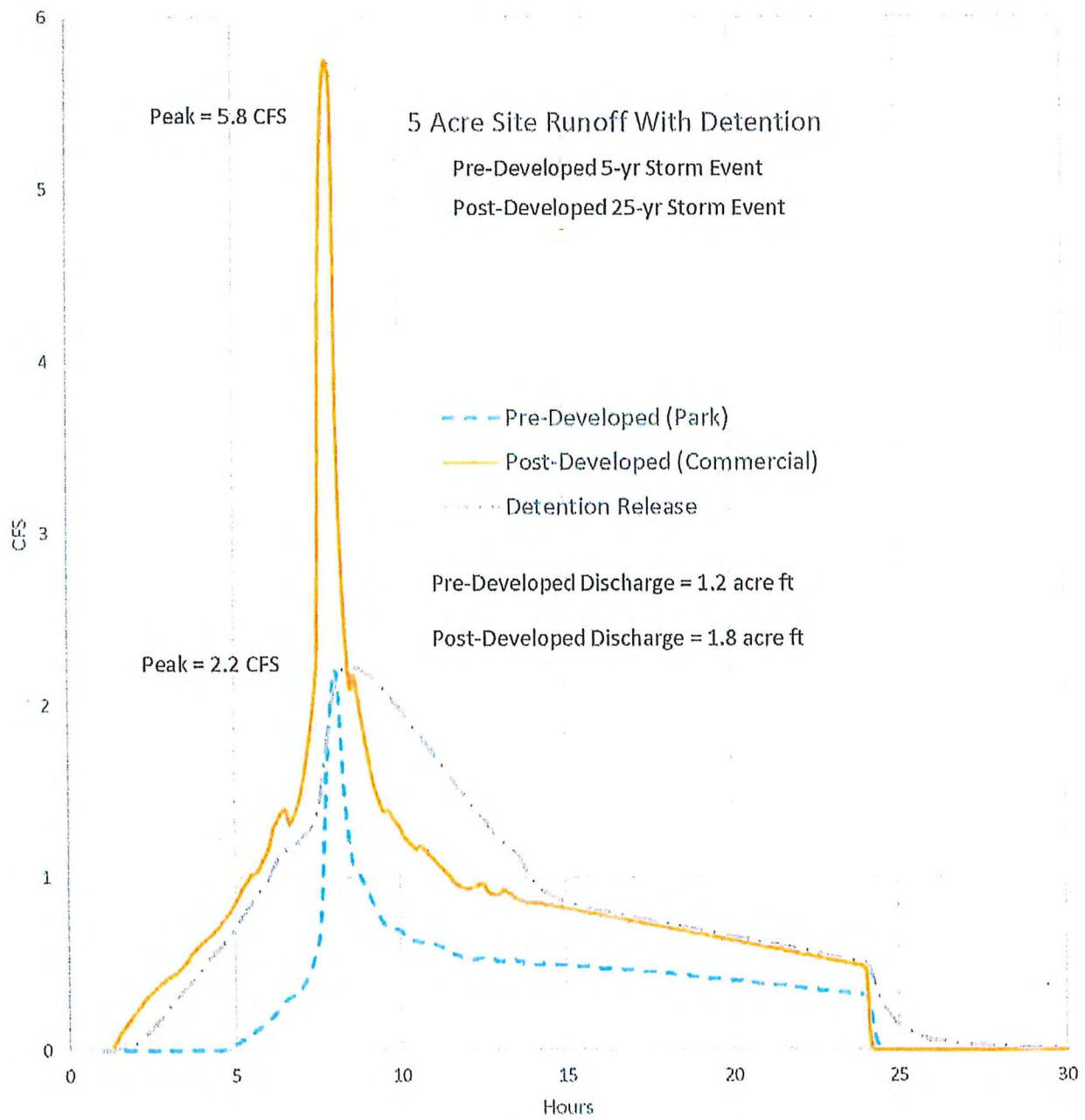
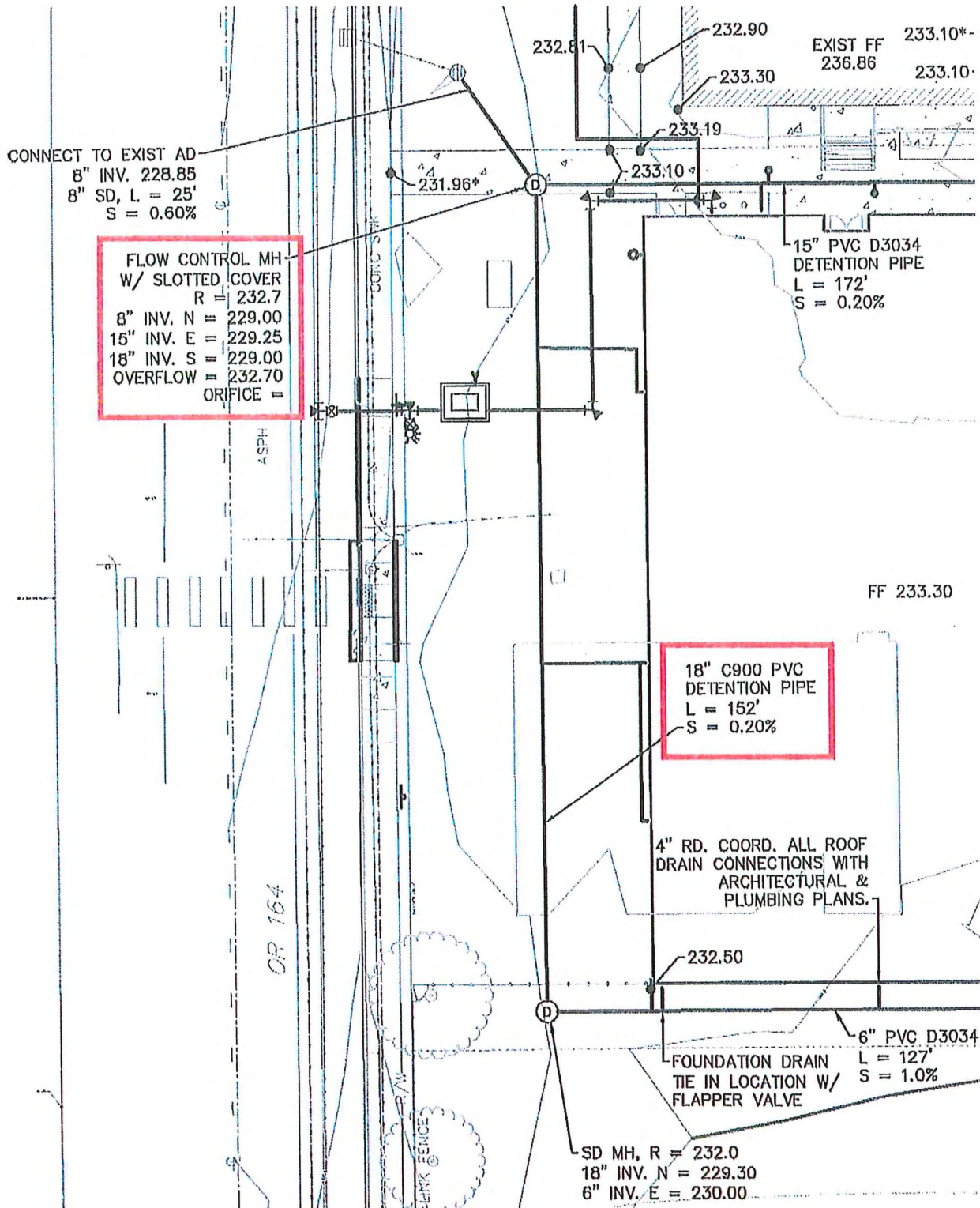



Figure 5-7 | Pipe Detention





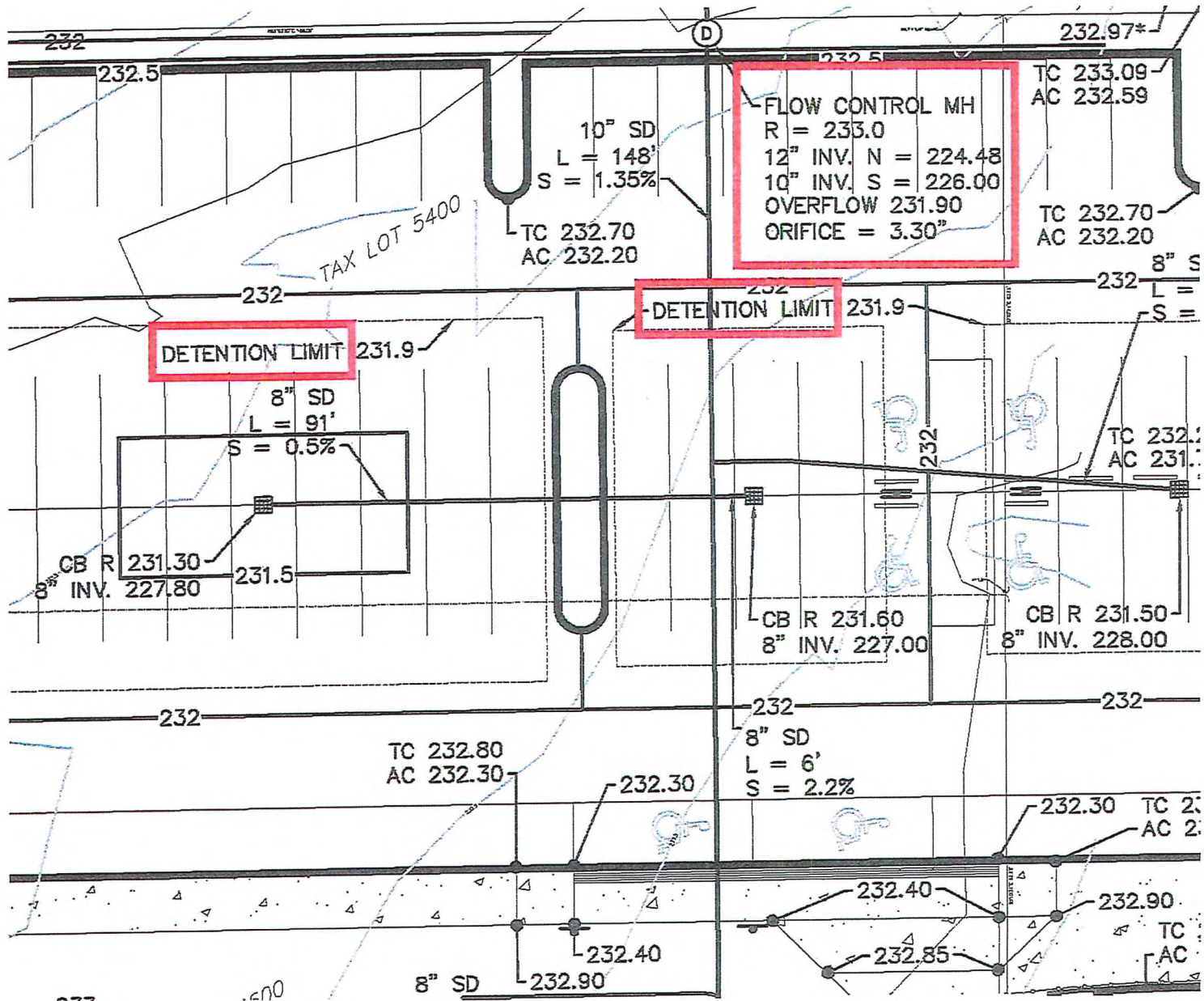
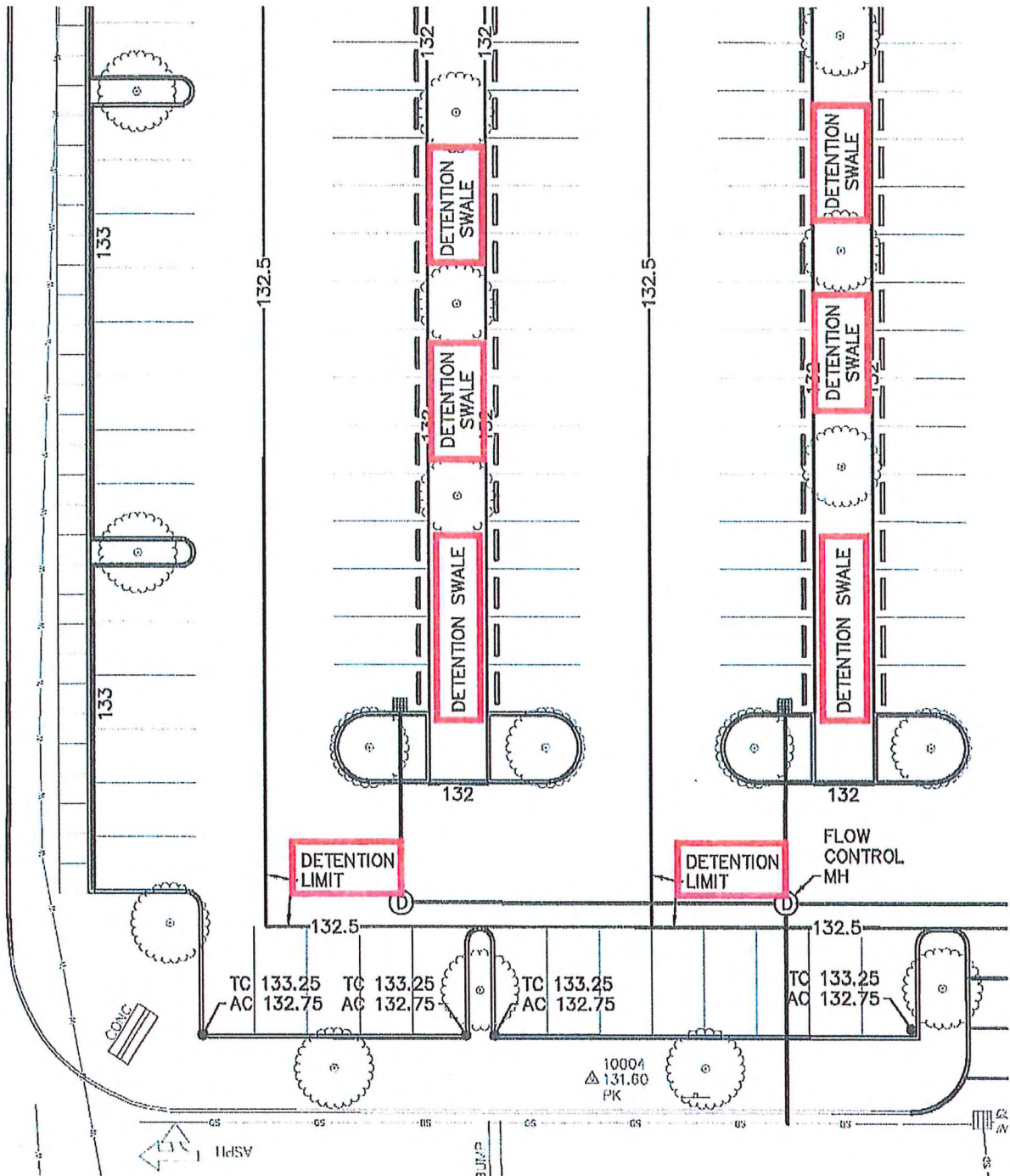
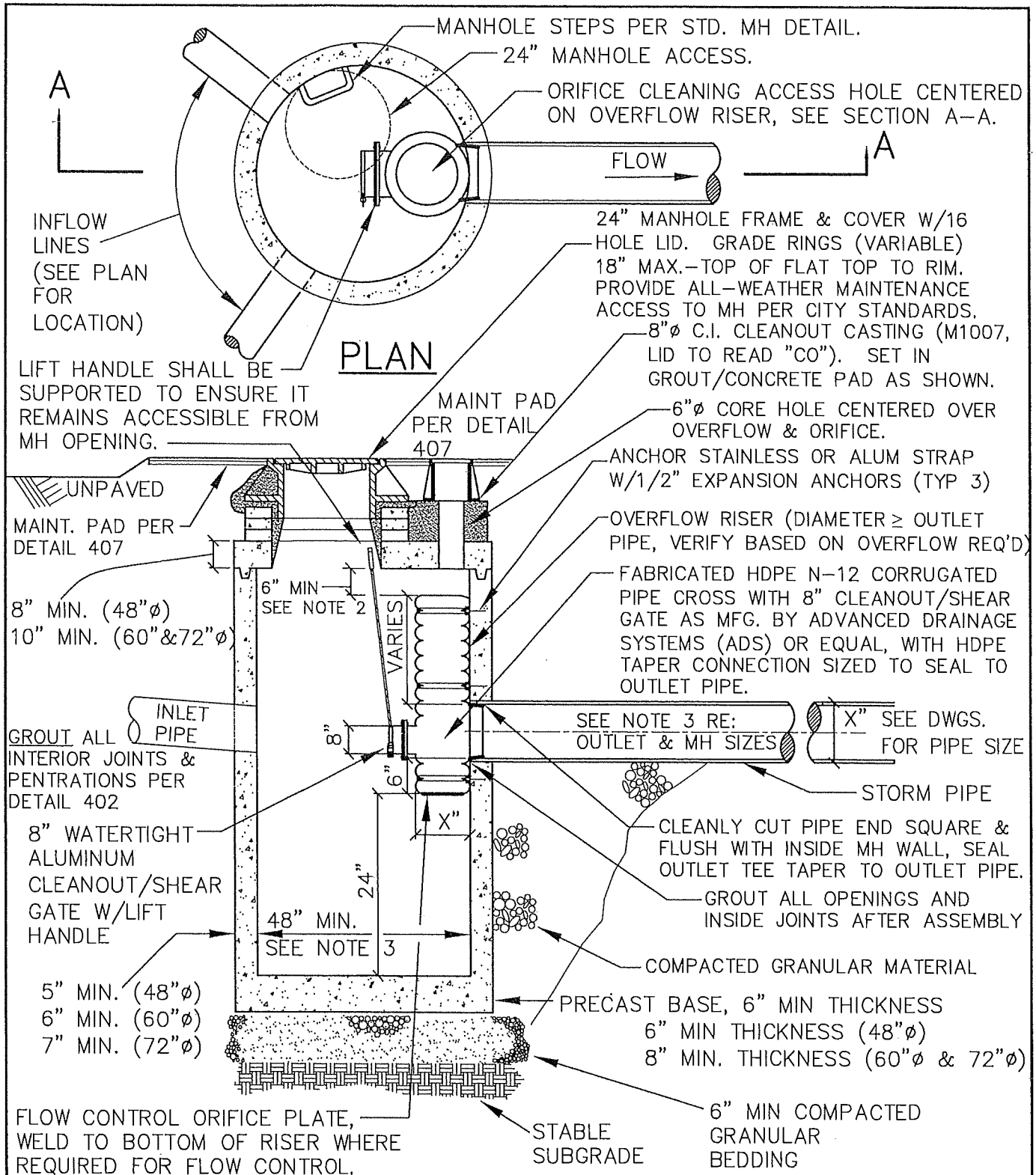

Figure 5-8 | Parking Lot Detention

Detention illustrative examples

Figure 5-9 | Parking Lot Swale Detention





### SECTION A-A

**NOTES:**

1. PRECAST SECTIONS SHALL CONFORM TO ASTM C-478.
2. DISTANCE FROM TOP OF OVERFLOW TO MH RIM SHALL BE BASED ON OVERFLOW CAPACITY CALC'S BY DESIGN ENGINEER (ASSUME ORIFICE CONTROL).
3. 60" MINIMUM DIA. MANHOLE REQUIRED FOR OUTLET PIPE LARGER THAN 15" OR INLET > 21".
4. ORIFICE CLEANING ACCESS TO BE 6" CORE HOLE THROUGH FLAT-TOP (CENTERED ON OVERFLOW) WITH CI CLEANOUT BOX GROUTED TO SLAB.

LAST REVISION DATE:	
AUG 2020	
<b>POLLUTION/FLOW CONTROL MANHOLE W/OVERFLOW</b>	
(NTS)	
DAYTON, OR	DETAIL NO. 320

Figure 5-11 | Flow Control Type III Inlet

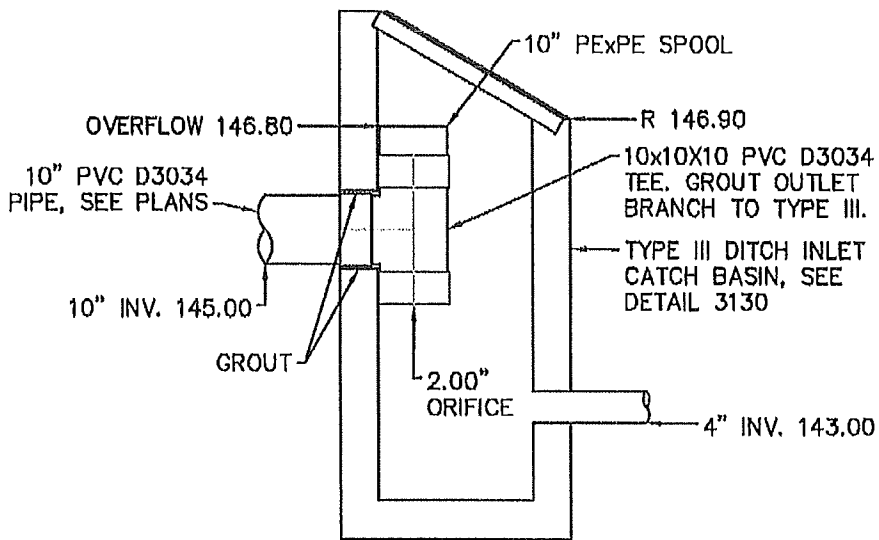

INSTALL 10" PLUG IN LOWER  
BRANCH OF THE 10x10x10 TEE  
W/ 2.00" DIA. HOLE DRILLED IN  
THE CENTER OF THE PLUG.

LAST REVISION DATE:	JO #
<b>TYPE III INLET FLOW CONTROL</b>	
(NTS)	
WESTECH ENG.	DETAIL NO. <b>EXHIBIT</b>